

TC1UxxSCyLCy

19" FIBER OPTIC SLIDING PANEL



+ BENEFITS

- Optimized depth: Easy fiber management.
- Multiple Cable Inputs.
- Easy installation.
- Easy opening for better access to the panel.



DESCRIPTION / APPLICATIONS

The TC 1U drawer is ideal for both vertical and horizontal applications of optical wiring in LAN application .

This 19" 1U optical steel panel has a sliding tray that tilts 45° when opened to facilitate implementation or maintenance. When it's closed, it provide a ip 30 protection.

The TC panel has got 2 differents versions, 12 or 24 adapters LC or SC, offering a capacity up to 96 optical connections.

It is supplied with screws for adapters, 2 cables glands and 4 buny clips for fiber management.

DRAWINGS AND DIMENSIONS

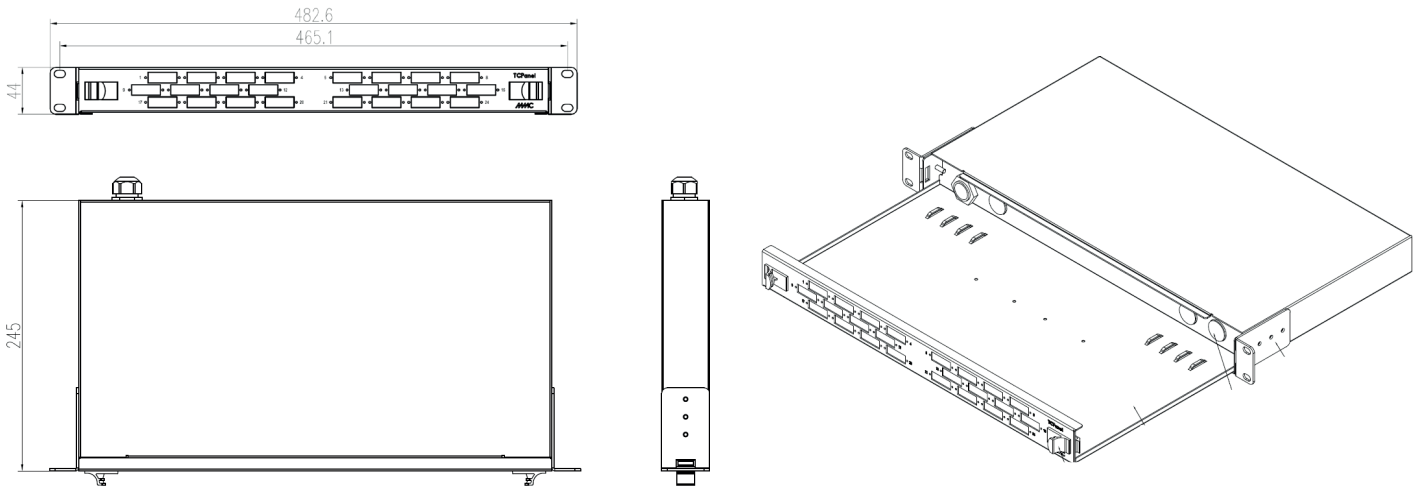

MECHANICAL PROPERTIES

Material	Steel sheet 1.2mm thickness
RAL	Dark grey RAL 7016
Inputs	4 dust proof cable entries for PG13.5 cable glands
System	Locking and closing by 2 black buttons
Dimensions	Width 482.6 mm (19") x depth 245 mm x height 44mm
Weight	2.5 Kg
Packaging	Unit

STANDARDS

Generic cabling specifications	ISO/IEC 11801 2nd Édition (Amd 2.0)
Insertion loss optical budget	EN 50173, IEEE 802.3ae
Optical transmission performance according to:	TIA/EIA-604-5
FOCIS (Fiber Optic Connectors Intermateability Standard)	TIA/EIA-568-C.3
Insertion cycles for interconnecting elements	TIA/EIA 455-21a
Optical performance of connectors	IEC-61754-20 (connecteurs LC) IEC-61754-14 (connecteurs SC)
Environmental protection according to:	2002/95/EC (RoHS) SvHC (Substance Very High Concern)

RELATED PRODUCT

ITEMS	DESCRIPTIONS
48K712F01598	Splice tray for 12 heat shrinks dimension 15 x 9.7 x 0.8 cm
48K724F02298	Splice tray for 24 heat shrinks dimension 22 x 9.7 x 0.8 cm
MANCHONEPI45150	Heat shrink splice protection tube 1.0/2.2 mm x length 45 mm
48MMTSCS	SC Simplex adapter for Multimode fiber
48SMTSCS	SC Simplex adapter for Singlemode fiber
48MMTSCD	SC Duplex adapter for Multimode fiber
48SMTSCD	SC Duplex adapter for Singlemode fiber
48MMTLCD	LC Duplex adapter for Multimode fiber
48SMTLCD	LC Duplex adapter for Singlemode fiber
48MMTLCQ	LC Quad adapter for Multimode fiber
48SMTLCQ	LC Quad adapter for Singlemode fiber

ORDER INFORMATION

ITEMS	DESCRIPTIONS	CONDITIONNEMENT
TC1U12SCDLCQ	19" 1U sliding panel for 12 SC Duplex or LC Quad adapters	Unit
TC1U12SCSLCD	19" 1U sliding panel for 12 SC Simplex or LC Duplex adapters	Unit
TC1U24SCDLCQ	19" 1U sliding panel for 24 SC Duplex or LC Quad adapters	Unit
TC1U24SCSLCD	19" 1U sliding panel for 24 SC Simplex or LC Duplex adapters	Unit