

NO24FDWA

Optical Duo Chassis - Dust & dirt protection - LC connectors - D serie - IP 65



+ ADVANTAGES

- Waterproof IP 65
- Dust & dirt protection
- Locking Push-Pull

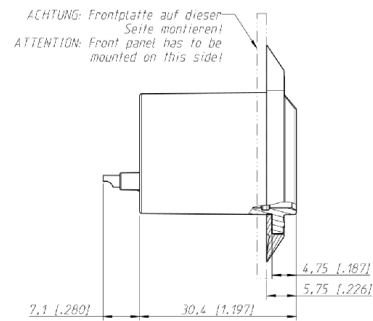
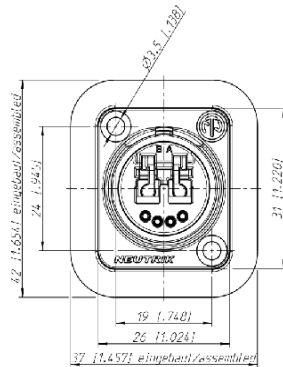

DESCRIPTION / APPLICATIONS

- Sound systems
- Lights
- Signage and LED screens

STANDARD

CONNECTOR : Certified ENEC - IEC 60320

and certified UL498

CLASS PROTECTION : IP 65

ELECTRICAL PROPERTIES

CONTACT RESISTANCE : 7 mΩ
DIELECTIC STRENGTH : 1.5 kVdc
INSULATION RESISTANCE : >2 GΩ
RATED CURRENT PER CONTACT : 6 A
RATED VOLTAGE : < 50 V

MECHANICAL/ TECHNICAL PROPERTIES

LIFETIME: >5 000
WIRESIZE : 2.5mm²
CONTACTS : Bronze
SHELL : Zinc diecast
INSERTION FORCE : < 45 N
WITHDRAWAL FORCE : < 45 N
LOCKING FORCE : 1 000 N

TEMPERATURE RANGE : -40°C à +75°C

ORDER INFORMATION

PART NB	DESCRIPTION	PACKAGING
NO24FDWA	EMB OPTICALCON DUO 4 CONT + 1LC	Individually (to confirm)